

## INSTALLATION PROCEDURE

READ INSTRUCTIONS BEFORE BEGINNING INSTALLATION

\*NOTE: DOES NOT FIT 2011 MODELS WITH POWER TAKE OFF.



Unit Code C409  
Part No. 425-5575

- 1 - Remove the two front passenger seat bolts. (Side panel will have to be removed to properly access outer bolt. Once base is installed, side panel should be set aside and not used.)
- 2 - Line up mounting base, insert original bolts and tighten.
- 3 - Assemble the desktop stand to the mount base, starting with the vertical tube. Use 2 Hex Head Cap Screws and 2 Lock Washers to secure vertical tube to mount post.
- 4 - Place articulated swing arm over the 5/8" end of the telescoping rod. Tighten with ratchet handle.
- 5 - Attach desktop to end of articulated swing arm and secure by tightening ratchet handle.

## STAND ASSEMBLY OPERATION



- 1 - Remove Hex Head Cap Screws from stand assembly and place tube over the No-Holes Mount Base.
- 2 - Thread (2) Hex Head Cap Screws with (2) Lock Washers through tube and into front and rear of No Holes Mount post at bottom of tube. (A)
- 3 - Raise inner rod to desired height. Thread (2) Hex Head Cap Screws with (2) Lock Washers into front and rear holes at top of tube. (B)
- 4 - Use provided Hex Key to tighten (4) Hex Head Cap Screws to ensure secure positioning.

## RATCHET CLAMP OPERATION

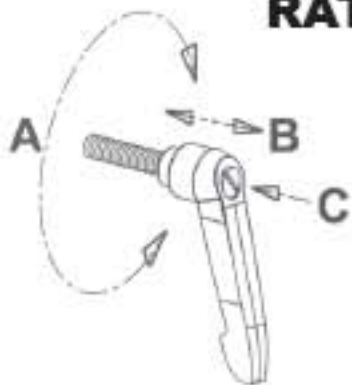

**NOTE:** Insert the ratchet handle through the unthreaded side of the articulated swing arm and tighten. Going through threaded side first will not allow the arm to tighten properly

To adjust, pull handle out (B) and rotate counter clockwise (A), release and tighten. If needed, use standard screwdriver in slot for adjustment (C)

**NOTE:** Ratchet handles are spring loaded and can be readjusted to tighten.

## SETTING UP THE "ACD" CABLE-DOCK DESKTOP

PLEASE CHECK ALL BOX FLAPS AND INSERTS FOR PARTS STORED UNDERNEATH BEFORE DISCARDING BOX!

### TOP VIEW



STEP 1:  
FOAM SHOCK PAD

### BOTTOM VIEW

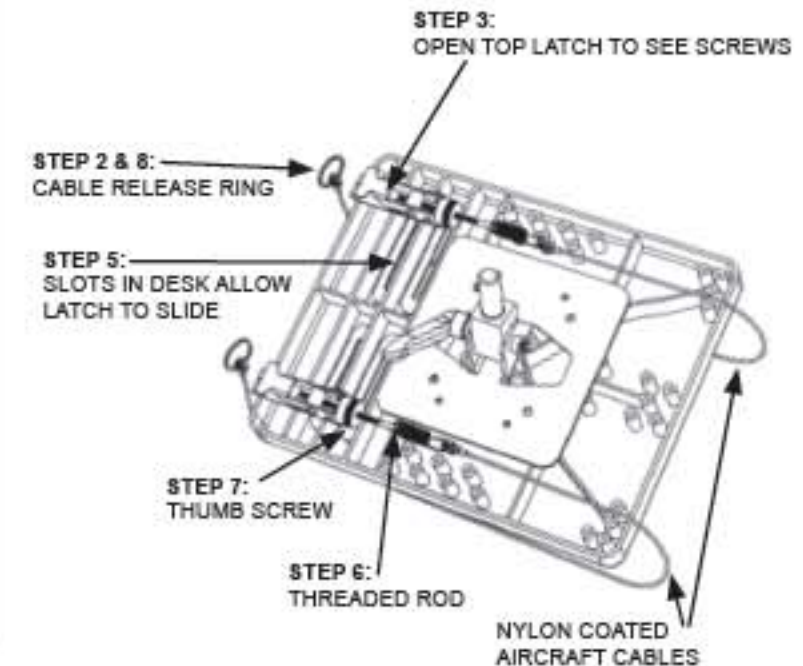

- STEP 1 Place the six foam shock pads on desktop surface in a similar pattern shown on top view.
  - STEP 2 Free cables from latches and flip desktop over, keep latches on left side.
  - STEP 3 Open top latch to access the two adjusting screws for properly locating the latch location in desk slots (you may need to screw the long threaded rod out of the way). Use a standard blade screwdriver to loosen (but not remove) the two bottom screws.
  - STEP 4 Turn desk right side up with the latches on the left side (as shown in top view.) Place computer on top and line up top cable to rest above the "F" (function) keys, then secure by throwing latch.
  - STEP 5 Slide bottom latch and cable to desired position, usually just below last row of keys and secure. If needed, fine tune bottom latch position. Now tighten the two latch screws.
  - STEP 6 Adjust the tightening tension of the cables by rolling the cable between the thumb and fingers. This will turn the threaded rod in the latch and thereby adjust the cable length to achieve the desired tension.
- CAUTION: DO NOT SHORTEN THE CABLES TO A POINT WHERE THE SPRING UNDER THE DESKTOP IS STRETCHED MORE THAN 2 OR 3 TIMES THE ORIGINAL LENGTH WHEN LATCH ASSEMBLY IS CLOSED.**
- STEP 7 To prevent release of latch, use thumb screw to tighten against the latch. To release the latch, back thumb screw one full turn and throw latch.
  - STEP 8 To release and secure cables, pull down on metal ring at end of cable and feed cable into the forked prongs attached to each latch. Pull down and away to remove.

**CAUTION SHORTENING THE CABLE LENGTH IN AN ATTEMPT TO MORE SECURELY HOLD THE LAPTOP IN PLACE COULD RESULT IN DAMAGE TO YOUR COMPUTER. THE SPRINGS UNDERNEATH THE DESKTOP SHOULD NEVER BE STRETCHED MORE THAN 2 OR 3 TIMES THE ORIGINAL LENGTH.**